

SR Scales®

“The Measure of Excellence”

Heavy Duty Scale
Model **SR**®V942

When you need a scale that is durable and heavy duty, consider the SRV942. While used primarily in stationary veterinary practices, this scale also has a wide range of application in the zoological field.

Constructed of stainless steel with a weighing capacity of 550 pounds, the SRV942 is extremely durable and provides consistent weight readings.

The rechargeable battery permits remote weighing when required. The SRV942 is equipped with a wall mount and power adaptor for stationary applications.

This scale is equipped with wheels and a fixed handle to allow for easy transport when required.

Whatever your weighing needs may be, **SR Scales**® is *“The measure of Excellence.”*



Stainless Steel Platform

Durable and Easy to Clean

Surface Mat

Removable for Quick and Easy Cleaning

Platform Size- 22”X 36”

Auto-Power Shutdown

Automatically Shuts down after Two Minutes

Multiple Power Source Options

Rechargeable battery with AC/DC Adaptor



SR® Instruments, Inc. 600 Young Street, Tonawanda, NY 14150 USA

PENN
SINCE 1981
Veterinary Supply, Inc.
Phone: 800.233.0210
www.pennvet.com

SYSTEM SPECIFICATIONS

Max Weight	550lb or 249kg
Display Resolution	.2 lb or .1kg
Display Units	Pounds/ Kilograms
Four Buttons	On/Zero/Off, Tare, Unit and Hold
Hold	Freezes the weight on the display
Tare	Allows objects to be placed on scale and zeroed out
Power	Rechargeable battery with DC Adaptor
Surface Mat	Removable for easy cleaning
Portability	Built-in handle and wheels
Auto- Power Down	Approximately two (2) minutes of non-use
Warranty	Two (2) Years

Heavy Duty Scale Model **SR**V942

DIMENSIONS in (cm)

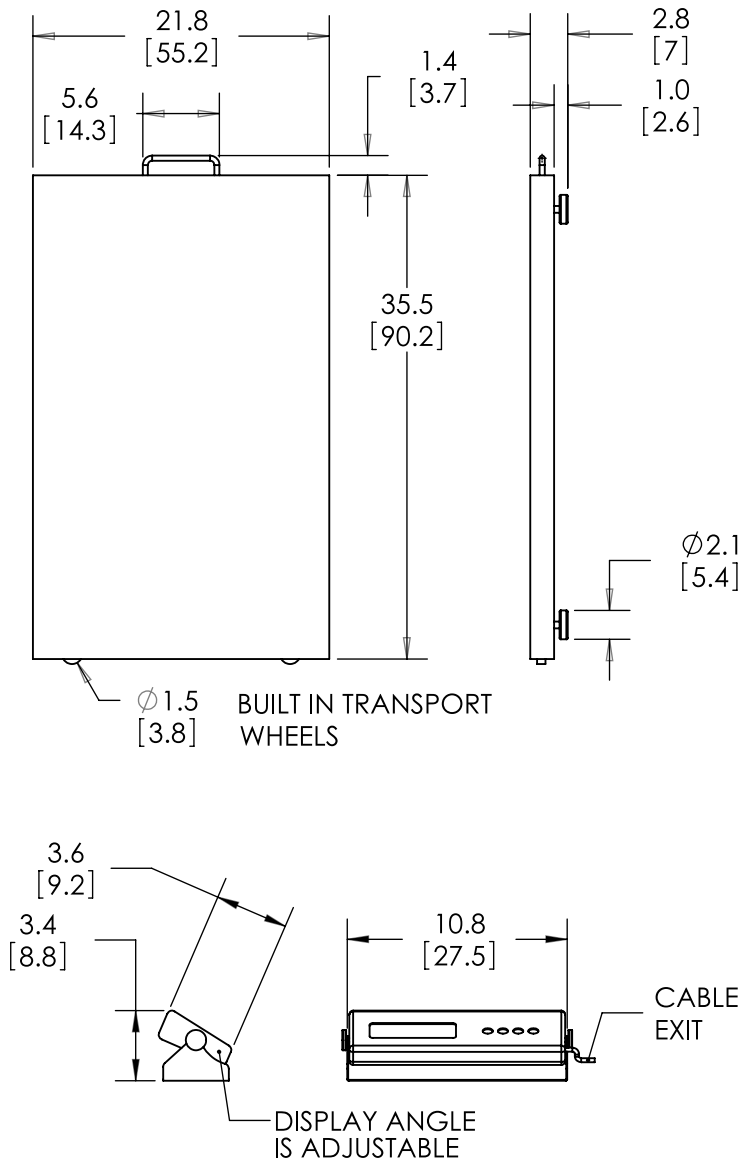

ACCESSORIES and OPTIONS

Description	Part Number
Replacement Mat	SRV942M
Replacement Charger	SRV942CH

PACKAGING

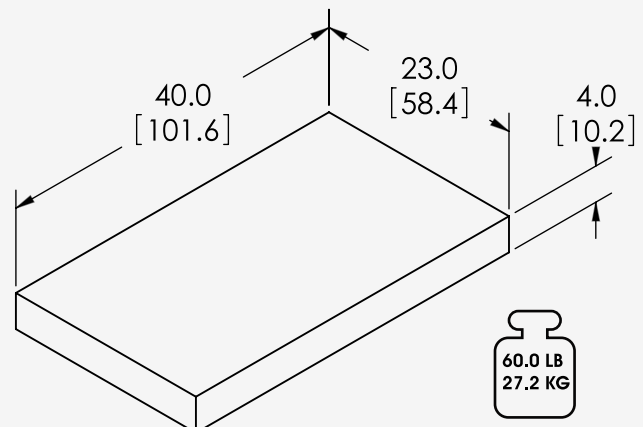

SR Scales®

“The Measure of Excellence”

In-Floor Scale Model SRV947IFS

The SRV947IFS is a flush mounted platform scale. This is a great alternative when floor space is at a premium. The flush surface eliminates tripping hazards and hallway accessibility issues.

The weighing surface is covered with a durable two part epoxy surface which provides years of maintenance-free service.

As a weighing station the scale will easily accommodate small and large animals. The large capacity allows pets to be easily weighed in kennels by taring out the kennel weight. The built-in surface ring makes cleaning underneath the scale a breeze.

Rugged and durable, this built to last scale comes with quality and reliability you've come to expect from SR Scales.



Weight Capacity - 400 Lbs. or 182 Kgs.

Always On - AC wall power means the scale is always on and ready to weigh

Auto-Hold - Scale will automatically lock in on weight above 1 Kilogram

Memory Recall - Recall the last stored weight



SR® Instruments, Inc. 600 Young Street, Tonawanda, NY 14150 USA

MADE IN THE USA  170228

SINCE 1981 **PENN**
Veterinary Supply, Inc.
Phone: 800.233.0210
www.pennvet.com

SYSTEM SPECIFICATIONS

Max Weight	400 Lb / 182 kg
Display Resolution	0.1 Lb/Kg
Accuracy	0.1% +/- 1 digit of displayed resolution
Display Units	Pounds / Kilograms
Power	120VAC 50-60 Hz
Memory	Press HOLD/RECALL to store the current weight. Pressing HOLD/RECALL again will retrieve the last stored weight.
Warranty	2 years

Note: Professional installation is required. Please consult with an SR team member prior to purchase.



In-Floor Scale

Model SRV947IFS

